

TAB4XLKL-B

Universal Aluminum Locking Tablet Holder

ARKON MOUNTS

Product Overview

- Sturdy aluminum holder is ideal for commercial or enterprise environments
 - Helps comply with FMCSA ELD Rule
- Universal holder adjusts to fit tablets up to 10"-12.9" screen size, even with protective cases
- Key lock keeps the tablet securely in place (keys included)

(Devices not included)

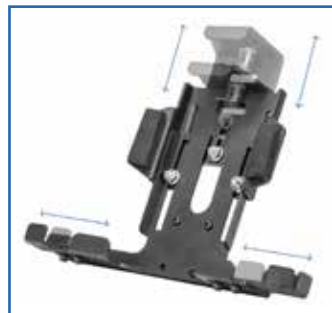

Tools Needed

- 7mm and 10mm socket wrenches

Compatible Products

Tablets with screen size 10"-12.9"

Product Specifications

Color: Black

Material: Aluminum

Holder Measurements:

Minimum width: 9.9" (251mm)

Maximum width: 12.25" (311mm)

Minimum height: 5.75" (146mm)

Maximum height: 9.75" (248mm)

Depth: .9" (23mm)

Weight: 13.5 ounces (384 grams)

Warranty: 2-year warranty

Country Designed: Designed in the USA

Country Manufactured: Made in Taiwan

UPC: 0-47407-40040-8

ARKON MOUNTS

Arkon Mounts
www.arkon.com
USA (800) 841-0884 | INT'L (626) 254-9005
20 La Porte Street | Arcadia, CA 91006 | USA



rev.020720